

## PRODUCT FEATURES

- 650V IGBT chip in trench FS-technology
- Low switching losses
- $V_{CE(sat)}$  with positive temperature coefficient
- Fast switching and short tail current
- Free wheeling diodes with fast and soft reverse recovery

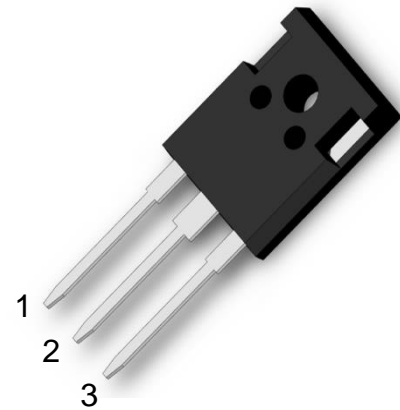

## APPLICATIONS

- High frequency switching application
- Medical applications
- Motion/servo control
- UPS systems

1.Gate  
2.Collector  
3.Emmitter

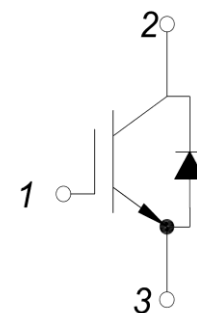

Type	$V_{CES}$	$I_C$	$V_{CE(sat)}$ $T_J=25^\circ C$	$T_{Jmax}$	Marking	Package
MM40G3U65B	650V	40A	1.75V	175°C	MM40G3U65B	TO-247

## ABSOLUTE MAXIMUM RATINGS( $T_C=25^\circ C$ unless otherwise specified)

Symbol	Parameter/Test Conditions	Values	Unit	
$V_{CES}$	Collector Emitter Voltage	$T_J=25^\circ C$	V	
$V_{GES}$	Gate Emitter Voltage			
$I_C$	DC Collector Current	$T_C=25^\circ C$	A	
		$T_C=100^\circ C$		
$I_{Cpuls}$	Pulsed collector current, tp limited by $T_{Jmax}$	120		
$P_{tot}$	Power Dissipation Per IGBT	230	W	
$V_{RRM}$	Repetitive Reverse Voltage	$T_J=25^\circ C$	V	
$I_{F(AV)}$	Average Forward Current	$T_C=25^\circ C$	A	
$I_{Fpuls}$	Diode pulsed current, tp limited by $T_{Jmax}$	80		
$T_{Jmax}$	Max. Junction Temperature	175	°C	
$T_{Jop}$	Operating Temperature	-40~175		
$T_{stg}$	Storage Temperature	-55~150		
Torque	to heatsink	Recommended (M3)	1.1	Nm
Weight			8	g

MacMic Science & Technology Co., Ltd.

Add: #18, Hua Shan Zhong Lu, New District, Changzhou City, Jiangsu Province, P. R. of China

Tel.: +86-519-85163708 Fax: +86-519-85162291 Post Code: 213022 Website: www.macmicst.com

# MM40G3U65B

## IGBT

### ELECTRICAL CHARACTERISTICS ( $T_C=25^\circ\text{C}$ unless otherwise specified)

Symbol	Parameter/Test Conditions		Min.	Typ.	Max.	Unit
$V_{GE(th)}$	Gate Emitter Threshold Voltage	$V_{CE}=V_{GE}, I_C=1.6\text{mA}$	4.5	5.2	6.0	V
$V_{CE(sat)}$	Collector Emitter Saturation Voltage	$I_C=40\text{A}, V_{GE}=15\text{V}, T_J=25^\circ\text{C}$		1.75	2.25	
		$I_C=40\text{A}, V_{GE}=15\text{V}, T_J=125^\circ\text{C}$		2.1		
		$I_C=40\text{A}, V_{GE}=15\text{V}, T_J=150^\circ\text{C}$		2.15		
$I_{CES}$	Collector Leakage Current	$V_{CE}=650\text{V}, V_{GE}=0\text{V}, T_J=25^\circ\text{C}$			100	$\mu\text{A}$
		$V_{CE}=650\text{V}, V_{GE}=0\text{V}, T_J=150^\circ\text{C}$			10	$\text{mA}$
$I_{GES}$	Gate Leakage Current	$V_{CE}=0\text{V}, V_{GE}=\pm 20\text{V}, T_J=25^\circ\text{C}$	-200		200	$\text{nA}$
$R_{gint}$	Integrated Gate Resistor			2		$\Omega$
$Q_g$	Gate Charge	$V_{CE}=300\text{V}, I_C=40\text{A}, V_{GE}=15\text{V}$		180		$\text{nC}$
$C_{ies}$	Input Capacitance	$V_{CE}=25\text{V}, V_{GE}=0\text{V}, f=1\text{MHz}$		1.8		$\text{nF}$
$C_{res}$	Reverse Transfer Capacitance				95	
$t_{d(on)}$	Turn on Delay Time	$V_{CC}=400\text{V}, I_C=40\text{A}$ $R_G=20\Omega,$ $V_{GE}=\pm 15\text{V},$ Inductive Load	$T_J=25^\circ\text{C}$		20	$\text{ns}$
			$T_J=125^\circ\text{C}$		25	$\text{ns}$
			$T_J=150^\circ\text{C}$		25	$\text{ns}$
$t_r$	Rise Time		$T_J=25^\circ\text{C}$		35	$\text{ns}$
			$T_J=125^\circ\text{C}$		40	$\text{ns}$
			$T_J=150^\circ\text{C}$		40	$\text{ns}$
$t_{d(off)}$	Turn off Delay Time	$T_J=25^\circ\text{C}$		200	$\text{ns}$	
		$T_J=125^\circ\text{C}$		230	$\text{ns}$	
		$T_J=150^\circ\text{C}$		240	$\text{ns}$	
$t_f$	Fall Time	$T_J=25^\circ\text{C}$		30	$\text{ns}$	
		$T_J=125^\circ\text{C}$		35	$\text{ns}$	
		$T_J=150^\circ\text{C}$		35	$\text{ns}$	
$E_{on}$	Turn on Energy	$T_J=125^\circ\text{C}$		1.75	$\text{mJ}$	
		$T_J=150^\circ\text{C}$		1.87	$\text{mJ}$	
$E_{off}$	Turn off Energy	$T_J=125^\circ\text{C}$		0.85	$\text{mJ}$	
		$T_J=150^\circ\text{C}$		0.9	$\text{mJ}$	
$I_{SC}$	Short Circuit Current	$tpsc \leq 6\mu\text{s}, V_{GE}=15\text{V}$ $T_J=125^\circ\text{C}, V_{CC}=360\text{V}$		230		A
$R_{thJC}$	Junction to Case Thermal Resistance ( Per IGBT )				0.65	$\text{K/W}$

## Anti-Parallel Diode

### ELECTRICAL CHARACTERISTICS ( $T_C=25^\circ\text{C}$ unless otherwise specified)

Symbol	Parameter/Test Conditions		Min.	Typ.	Max.	Unit
$V_F$	Forward Voltage	$I_F=40\text{A}, V_{GE}=0\text{V}, T_J=25^\circ\text{C}$		2.15	2.6	V
		$I_F=40\text{A}, V_{GE}=0\text{V}, T_J=125^\circ\text{C}$		1.85		
		$I_F=40\text{A}, V_{GE}=0\text{V}, T_J=150^\circ\text{C}$		1.75		
$t_{rr}$	Reverse Recovery Time	$I_F=40\text{A}, V_R=400\text{V}$ $di_F/dt=-800\text{A}/\mu\text{s}$ $T_J=150^\circ\text{C}$		180		$\text{ns}$
$I_{RRM}$	Max. Reverse Recovery Current			25		A
$Q_{RR}$	Reverse Recovery Charge			2.1		$\mu\text{C}$
$E_{rec}$	Reverse Recovery Energy			0.42		$\text{mJ}$
$R_{thJCD}$	Junction to Case Thermal Resistance ( Per Diode )				1.5	$\text{K/W}$

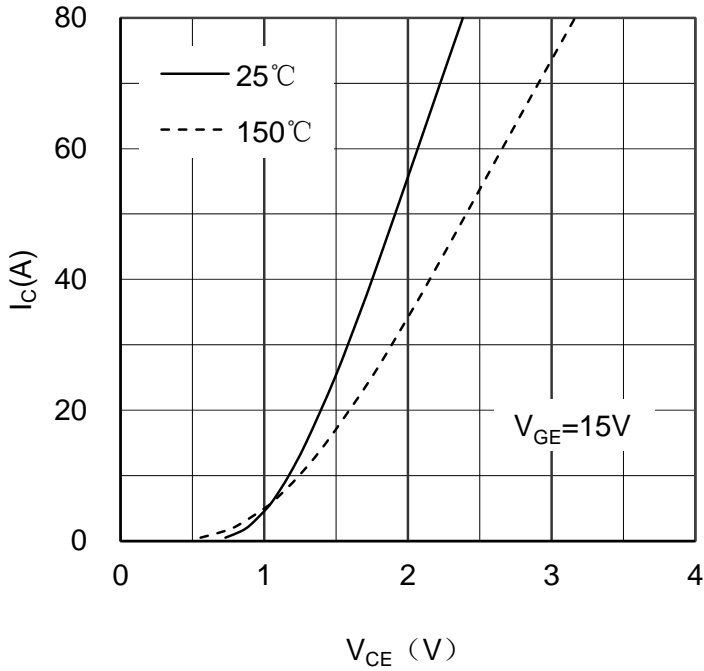

Figure 1. Typical Output Characteristics IGBT

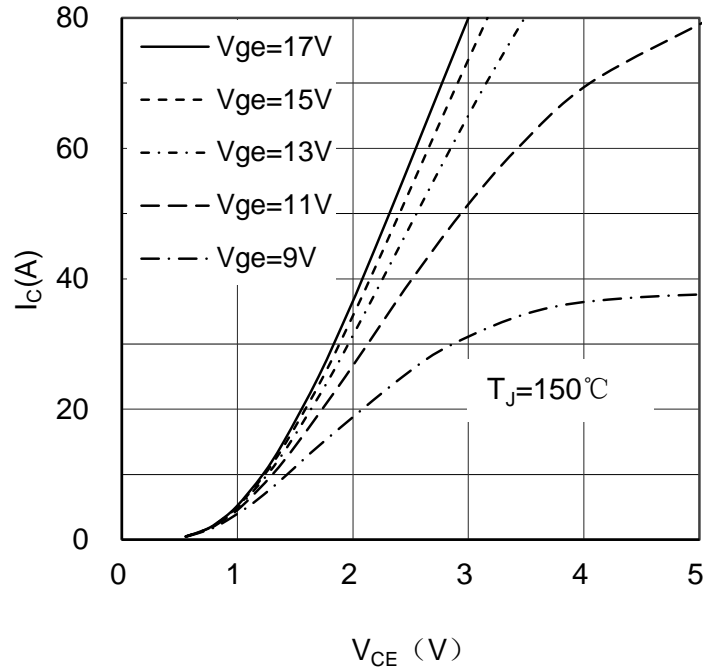

Figure 2. Typical Output Characteristics IGBT

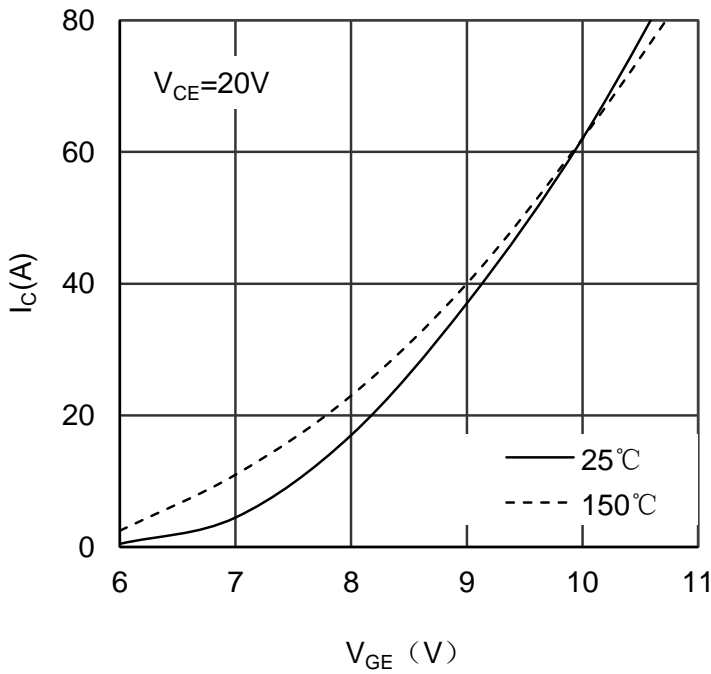

Figure 3. Typical Transfer characteristics IGBT

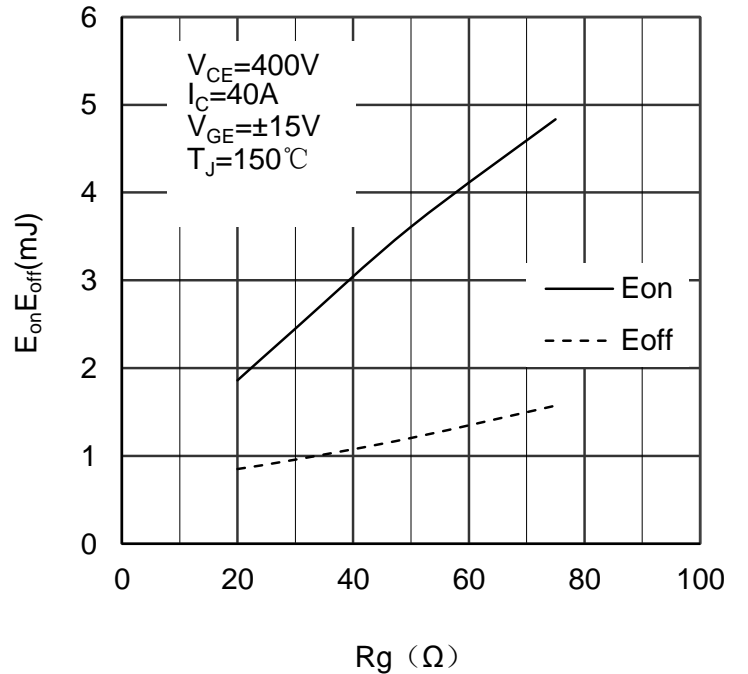

Figure 4. Switching Energy vs Gate Resistor IGBT

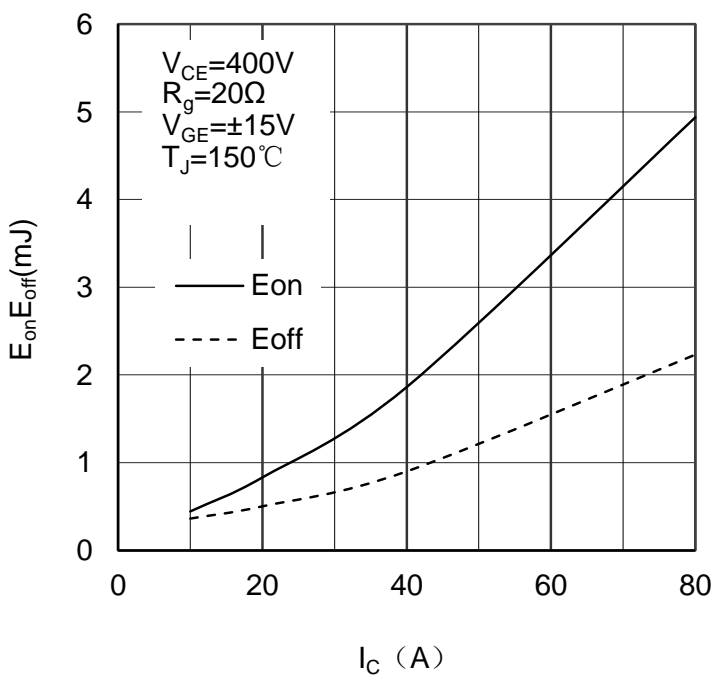

Figure 5. Switching Energy vs Collector Current IGBT

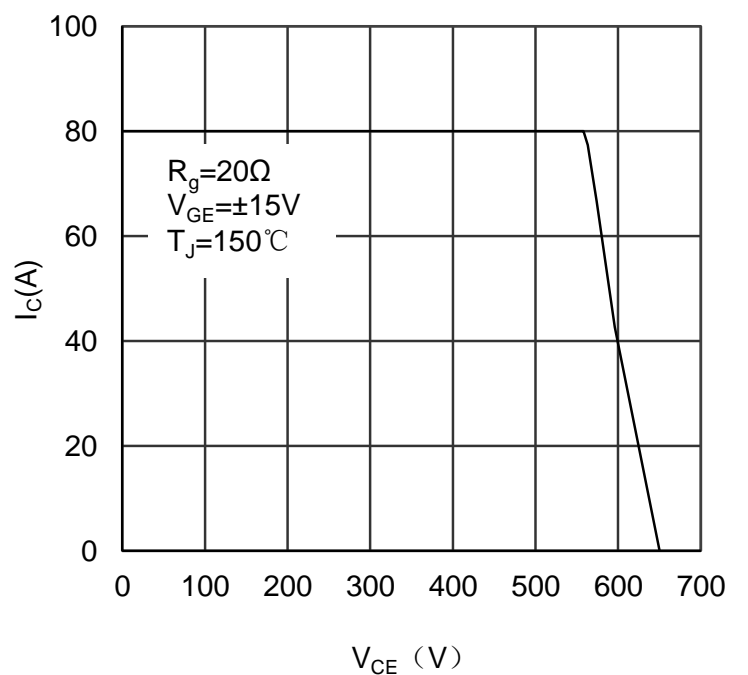

Figure 6. Reverse Biased Safe Operating Area IGBT

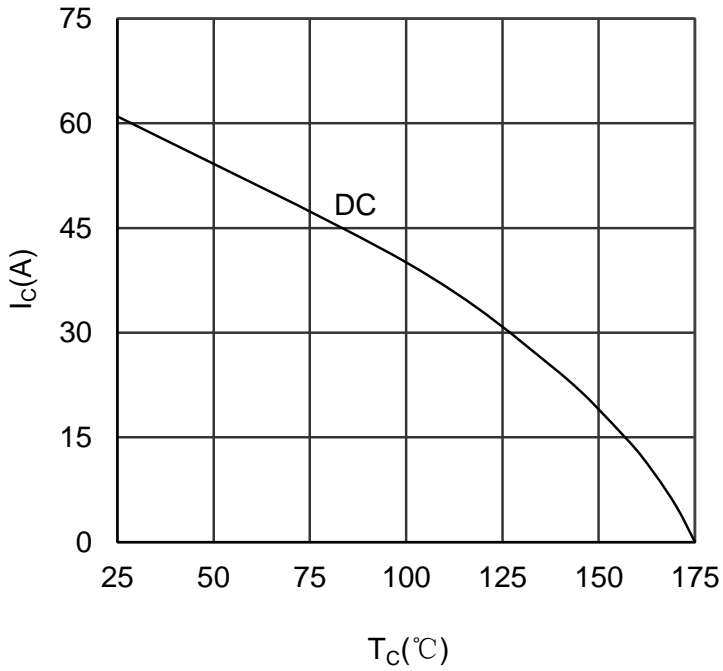

Figure 7. Collector Current vs Case temperature IGBT

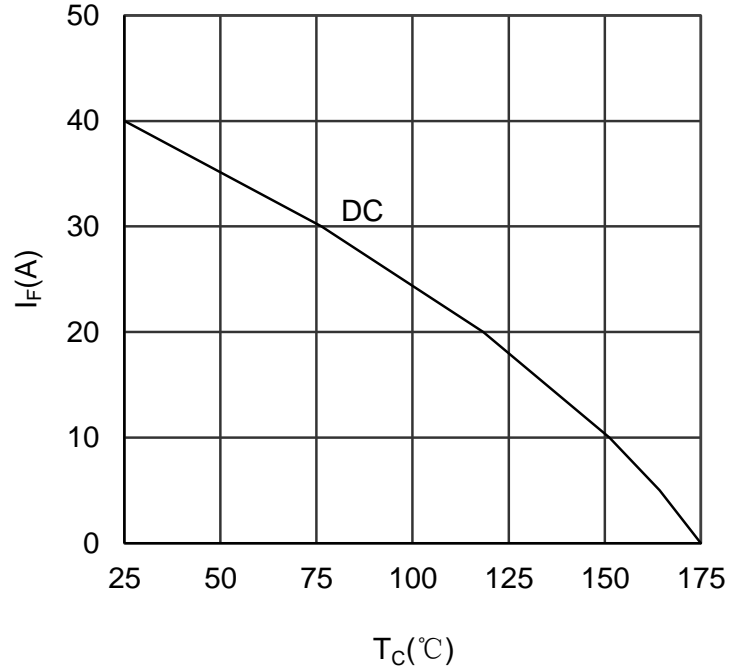

Figure 8. Forward current vs Case temperature Diode

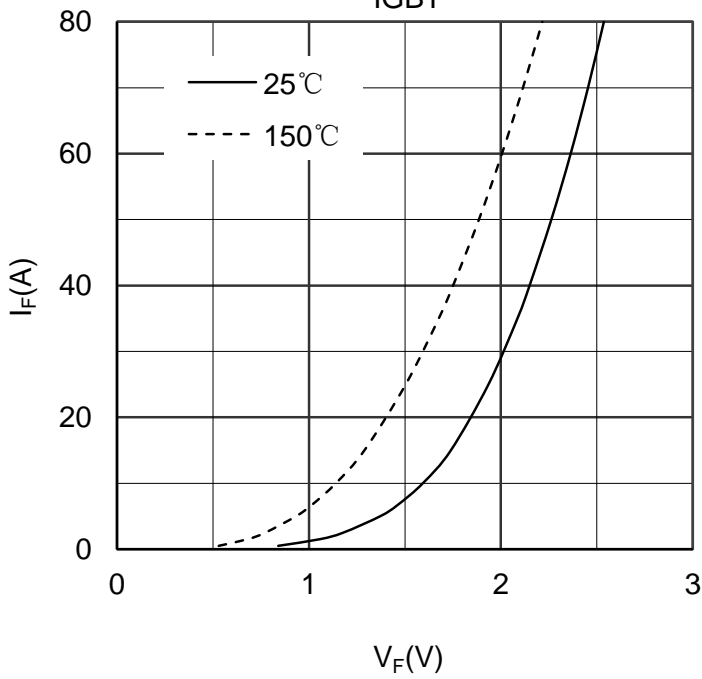

Figure 9. Diode Forward Characteristics Diode

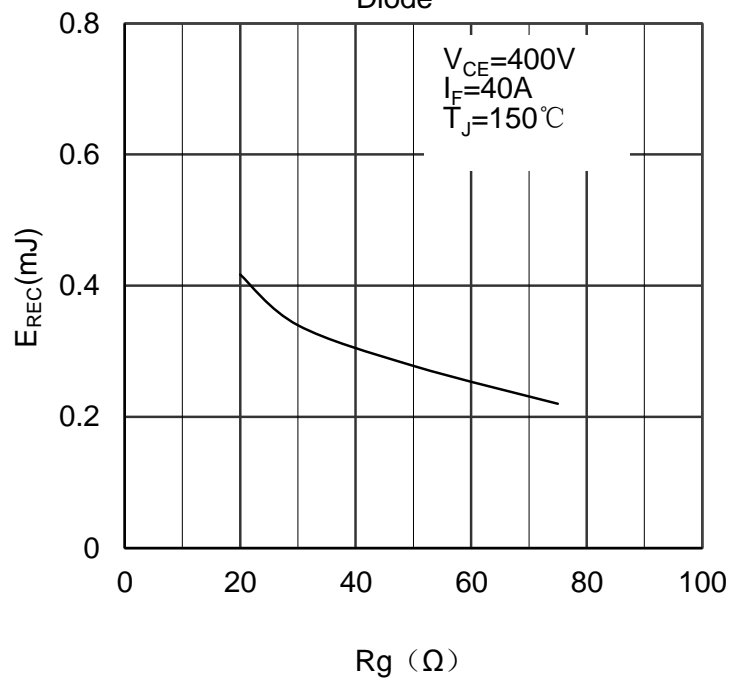

Figure 10. Switching Energy vs Gate Resistor Diode

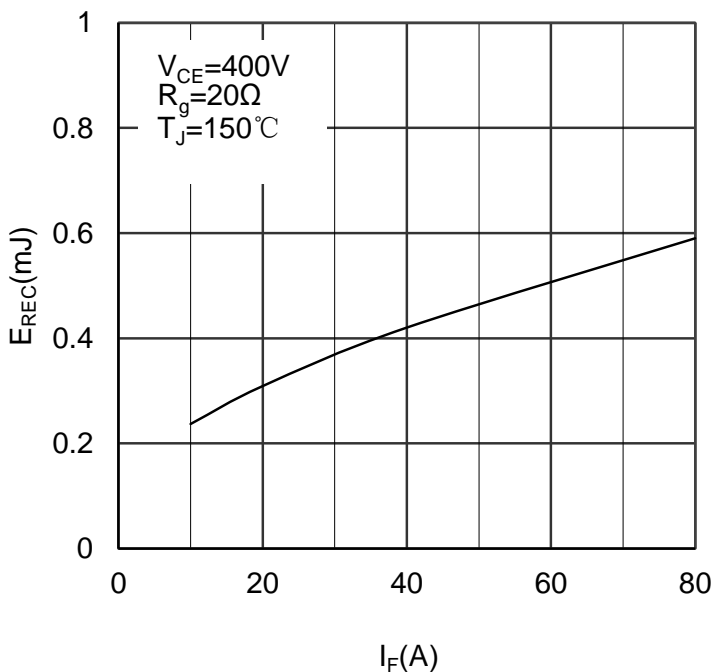

Figure 11. Switching Energy vs Forward Current Diode

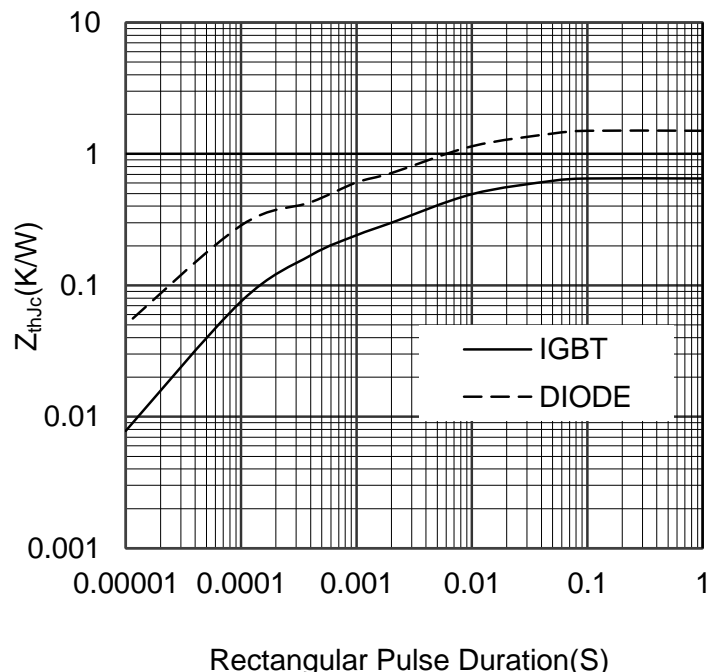
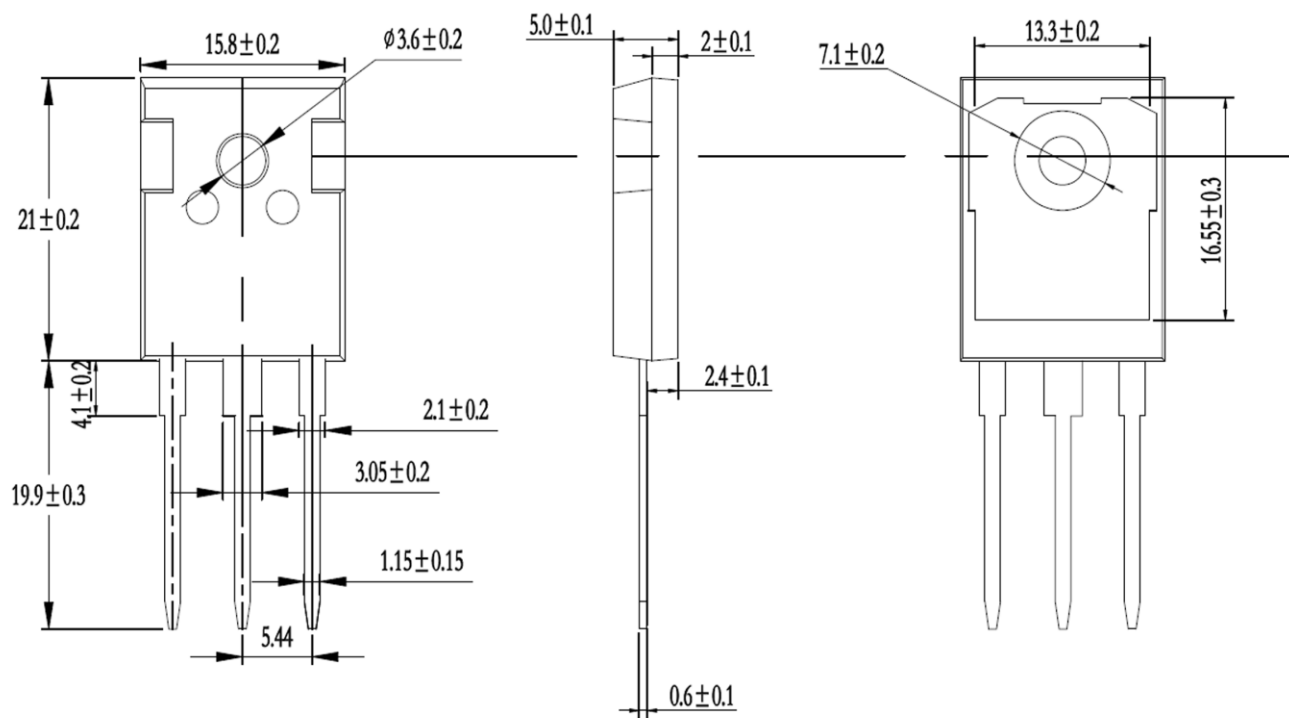

Figure 12. Transient Thermal Impedance of Diode and IGBT



Dimensions in (mm)  
Figure 13. Package Outline