

## PRODUCT FEATURES

- IGBT3 CHIP(1700V Trench+Field Stop technology)
- Low turn-off losses, short tail current
- $V_{CE(sat)}$  with positive temperature coefficient
- DIODE CHIP(1700V EMCON 3 technology)
- Free wheeling diodes with fast and soft reverse recovery



## APPLICATIONS

- High frequency switching application
- Medical applications
- Motion/servo control
- UPS systems

## IGBT-inverter

### ABSOLUTE MAXIMUM RATINGS

$T_C=25^{\circ}\text{C}$  unless otherwise specified

Symbol	Parameter/Test Conditions		Values	Unit
$V_{CES}$	Collector Emitter Voltage	$T_J=25^{\circ}\text{C}$	1700	V
$V_{GES}$	Gate Emitter Voltage		$\pm 20$	
$I_C$	DC Collector Current	$T_C=25^{\circ}\text{C}$	600	A
		$T_C=90^{\circ}\text{C}$	400	
$I_{CM}$	Repetitive Peak Collector Current	$t_p=1\text{ms}$	800	
$P_{tot}$	Power Dissipation Per IGBT		2700	W

## Diode-inverter

### ABSOLUTE MAXIMUM RATINGS

$T_C=25^{\circ}\text{C}$  unless otherwise specified

Symbol	Parameter/Test Conditions		Values	Unit
$V_{RRM}$	Repetitive Reverse Voltage	$T_J=25^{\circ}\text{C}$	1700	V
$I_{F(AV)}$	Average Forward Current	$T_C=25^{\circ}\text{C}$	400	A
$I_{FRM}$	Repetitive Peak Forward Current	$t_p=1\text{ms}$	800	
$i^2t$		$T_J=125^{\circ}\text{C}$ , $t=10\text{ms}$ , $V_R=0\text{V}$	24000	$\text{A}^2\text{S}$

**IGBT-inverter**  
**ELECTRICAL CHARACTERISTICS**
 $T_C = 25^\circ\text{C}$  unless otherwise specified

Symbol	Parameter/Test Conditions		Min.	Typ.	Max.	Unit
$V_{GE(th)}$	Gate Emitter Threshold Voltage	$V_{CE}=V_{GE}, I_C=16\text{mA}$	5.2	5.8	6.4	V
$V_{CE(sat)}$	Collector Emitter Saturation Voltage	$I_C=400\text{A}, V_{GE}=15\text{V}, T_J=25^\circ\text{C}$		2	2.45	
		$I_C=400\text{A}, V_{GE}=15\text{V}, T_J=125^\circ\text{C}$		2.4		
$I_{CES}$	Collector Leakage Current	$V_{CE}=1700\text{V}, V_{GE}=0\text{V}, T_J=25^\circ\text{C}$			3	mA
		$V_{CE}=1700\text{V}, V_{GE}=0\text{V}, T_J=125^\circ\text{C}$			20	mA
$I_{GES}$	Gate Leakage Current	$V_{CE}=0\text{V}, V_{GE}=\pm 15\text{V}, T_J=25^\circ\text{C}$	-400		400	nA
$R_{gint}$	Integrated Gate Resistor			1.9		$\Omega$
$Q_g$	Gate Charge	$V_{CE}=900\text{V}, I_C=400\text{A}, V_{GE}=\pm 15\text{V}$		4.8		$\mu\text{C}$
$C_{ies}$	Input Capacitance	$V_{CE}=25\text{V}, V_{GE}=0\text{V}, f=1\text{MHz}$		36		nF
$C_{res}$	Reverse Transfer Capacitance				1200	
$t_{d(on)}$	Turn on Delay Time	$V_{CC}=900\text{V}, I_C=400\text{A}$ $R_G=3.3\Omega,$ $V_{GE}=\pm 15\text{V},$ Inductive Load	$T_J=25^\circ\text{C}$		380	ns
			$T_J=125^\circ\text{C}$		420	ns
$t_r$	Rise Time	Inductive Load	$T_J=25^\circ\text{C}$		80	ns
			$T_J=125^\circ\text{C}$		100	ns
$t_{d(off)}$	Turn off Delay Time	$V_{CC}=900\text{V}, I_C=400\text{A}$ $R_G=3.3\Omega,$ $V_{GE}=\pm 15\text{V},$ Inductive Load	$T_J=25^\circ\text{C}$		800	ns
			$T_J=125^\circ\text{C}$		1000	ns
$t_f$	Fall Time	Inductive Load	$T_J=25^\circ\text{C}$		180	ns
			$T_J=125^\circ\text{C}$		300	ns
$E_{on}$	Turn on Energy	$V_{CC}=900\text{V}, I_C=400\text{A}$ $R_G=3.3\Omega,$ $V_{GE}=\pm 15\text{V},$ Inductive Load	$T_J=25^\circ\text{C}$		116	mJ
			$T_J=125^\circ\text{C}$		156	mJ
$E_{off}$	Turn off Energy	Inductive Load	$T_J=25^\circ\text{C}$		83	mJ
			$T_J=125^\circ\text{C}$		126	mJ
$I_{sc}$	Short Circuit Current	$tp_{sc} \leq 10\mu\text{s}, V_{GE}=15\text{V}$ $T_J=125^\circ\text{C}, V_{CC}=1000\text{V}$		1600		A
$R_{thJC}$	Junction to Case Thermal Resistance ( Per IGBT )				0.055	K/W

**Diode-inverter**  
**ELECTRICAL CHARACTERISTICS**
 $T_C = 25^\circ\text{C}$  unless otherwise specified

Symbol	Parameter/Test Conditions		Min.	Typ.	Max.	Unit
$V_F$	Forward Voltage	$I_F=400\text{A}, V_{GE}=0\text{V}, T_J=25^\circ\text{C}$		1.8	2.2	V
		$I_F=400\text{A}, V_{GE}=0\text{V}, T_J=125^\circ\text{C}$		1.9		
$I_{RRM}$	Max. Reverse Recovery Current	$I_F=400\text{A}, V_R=900\text{V}$		480		A
$Q_{RR}$	Reverse Recovery Charge	$dI_F/dt=-2700\text{A}/\mu\text{s}$		160		$\mu\text{C}$
$E_{rec}$	Reverse Recovery Energy	$T_J=125^\circ\text{C}$		96		mJ
$R_{thJCD}$	Junction to Case Thermal Resistance ( Per Diode )				0.1	K/W

**MODULE CHARACTERISTICS**

*T<sub>C</sub>=25°C unless otherwise specified*

Symbol	Parameter/Test Conditions		Values	Unit
T <sub>Jmax</sub>	Max. Junction Temperature		175	°C
T <sub>Jop</sub>	Operating Temperature		-40~150	
T <sub>stg</sub>	Storage Temperature		-40~125	
V <sub>isol</sub>	Isolation Breakdown Voltage	AC, 50Hz(R.M.S), t=1minute	4000	V
CTI	Comparative Tracking Index		> 225	
Torque	to heatsink	Recommended (M6)	3~5	Nm
	to terminal	Recommended (M6)	2.5~5	Nm
Weight			300	g

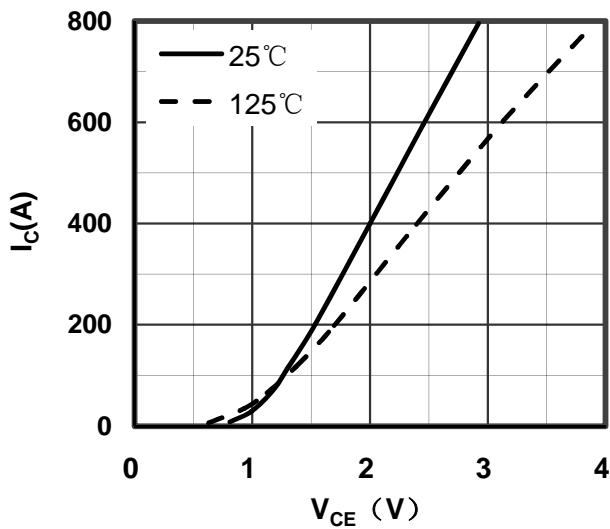

Figure 1. Typical Output Characteristics IGBT-inverter

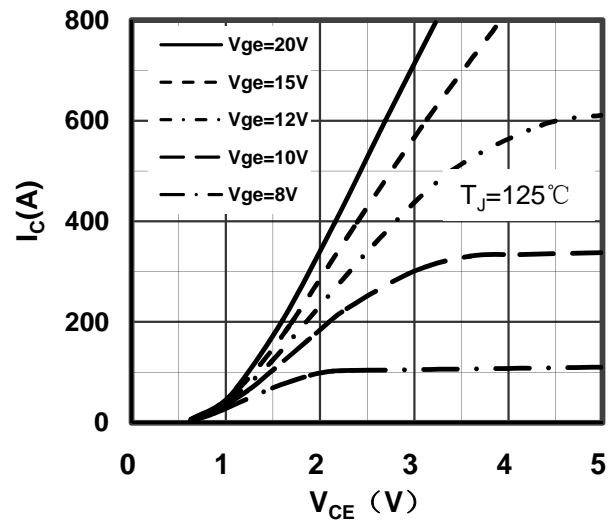

Figure 2. Typical Output Characteristics IGBT-inverter

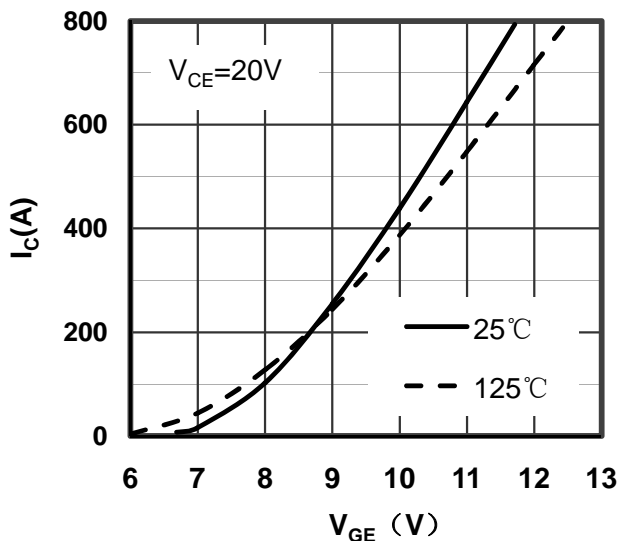

Figure 3. Typical Transfer Characteristics IGBT-inverter

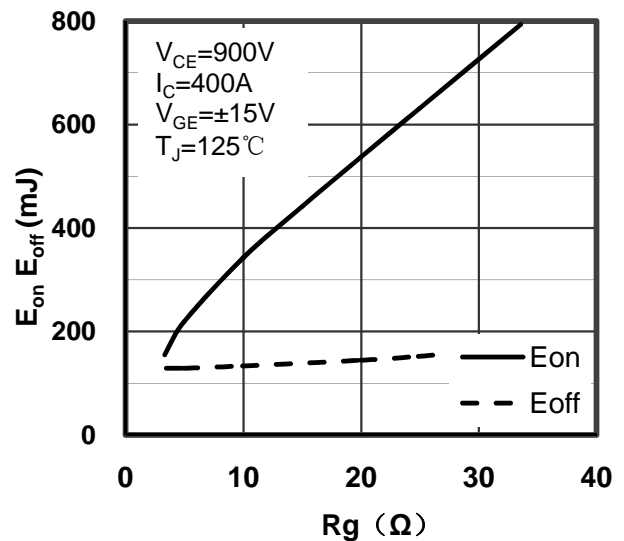

Figure 4. Switching Energy vs Gate Resistor IGBT-inverter

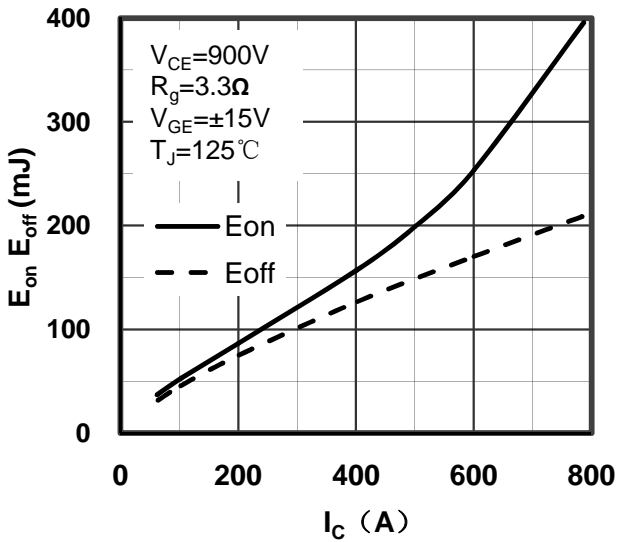

Figure 5. Switching Energy vs Collector Current IGBT-inverter

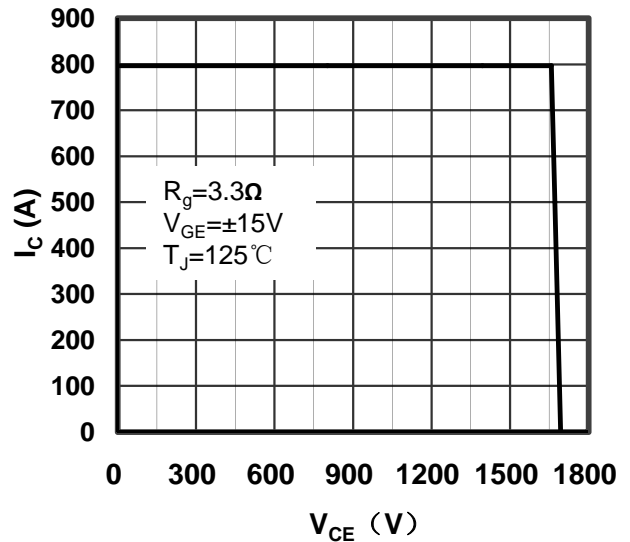

Figure 6. Reverse Biased Safe Operating Area IGBT-inverter

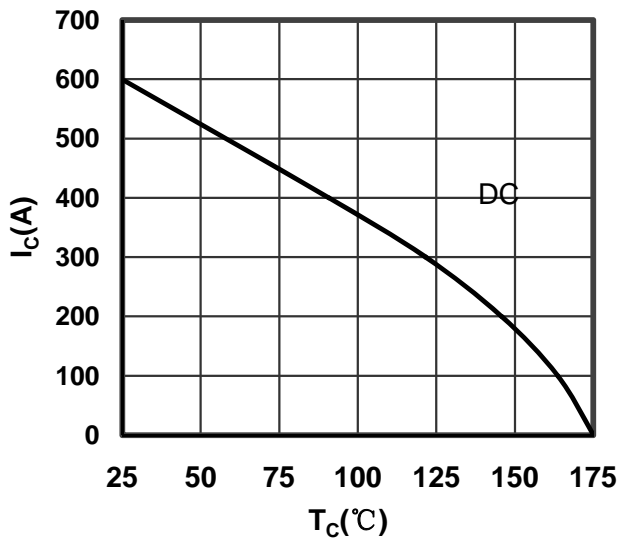

Figure 7. Collector Current vs Case temperature IGBT-inverter

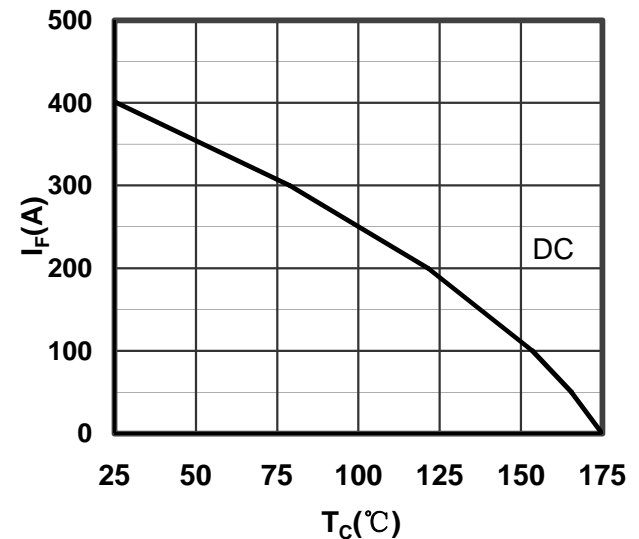

Figure 8. Forward current vs Case temperature Diode-inverter

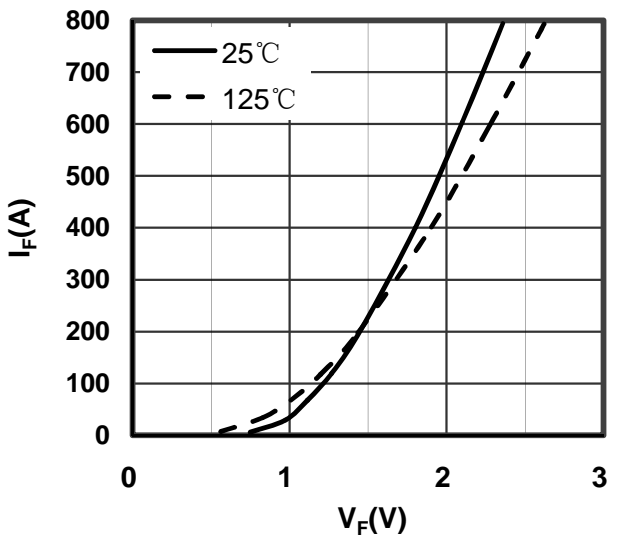

Figure 9. Diode Forward Characteristics Diode-inverter

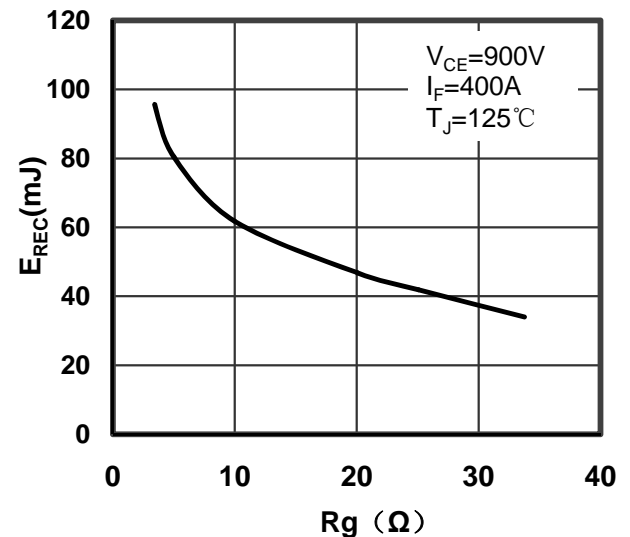

Figure 10. Switching Energy vs Gate Resistor Diode-inverter

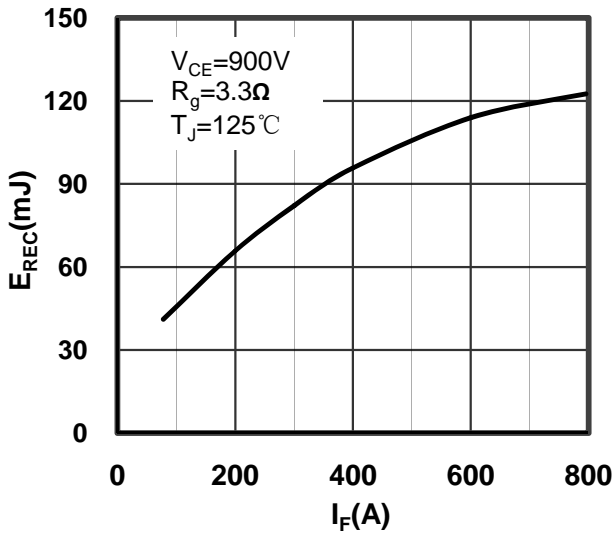

Figure 11. Switching Energy vs Forward Current Diode-inverter

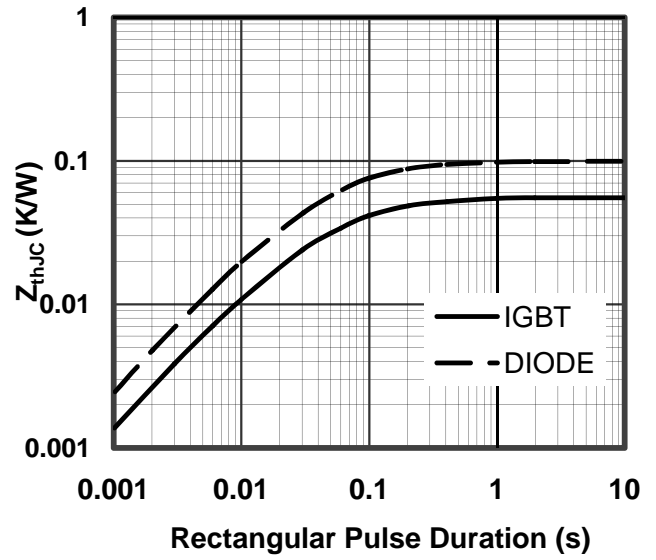

Figure 12. Transient Thermal Impedance of Diode and IGBT-inverter

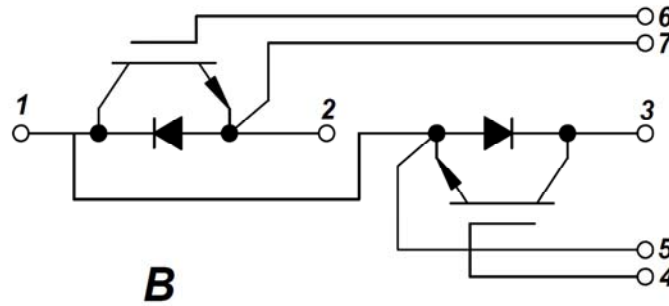
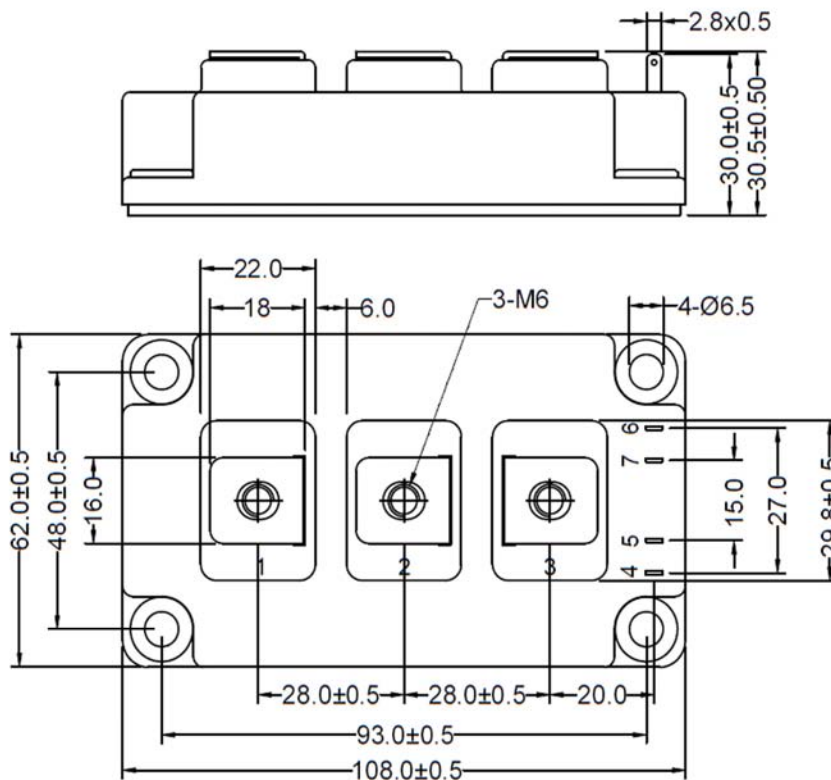

Figure 13. Circuit Diagram



Dimensions in (mm)  
Figure 14. Package Outline